

**INSTALLATION
INSTRUCTIONS**

Accessory

**CARGO NET
P/N 08L96-SDA-100**

Application

**2004 ACCORD
4-DOOR**

Publications No.

All 25751

Issue Date

AUG 2003**PARTS LIST**

Cargo net

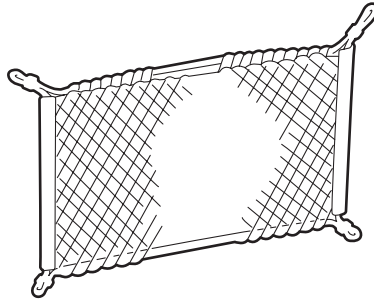

2 Anchors



Washer-bolt, 6 x 20 mm

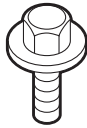

4 Self-tapping hooks



2 Nuts



Washer-bolt, 6 x 32 mm

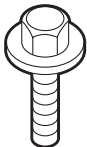

4 Spacers

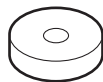
**TOOLS AND SUPPLIES REQUIRED**

Ratchet

8 mm Socket

10 mm Combination wrench

Clip remover

Drill

3 mm, 5 mm, and 10 mm Drill bits

26 mm Hole saw

Eye protection (face shield, safety goggles, etc.)

Masking tape

Tape measure

Felt-tip pen

Pushpin

White paint pen

INSTALLATION

Customer information: The information in this installation instruction is intended for use only by skilled technicians who have the proper tools, equipment, and training to correctly and safely add equipment to your vehicle. These procedures should not be attempted by "do-it-yourselfers."

NOTE: These instructions show the right anchor and hooks being installed. The same procedure applies to install the left anchor and hooks.

Installing the Hooks and Anchors

1. Open the trunk, and remove one clip from the front of the spare tire lid. Take out the spare tire lid from the trunk.

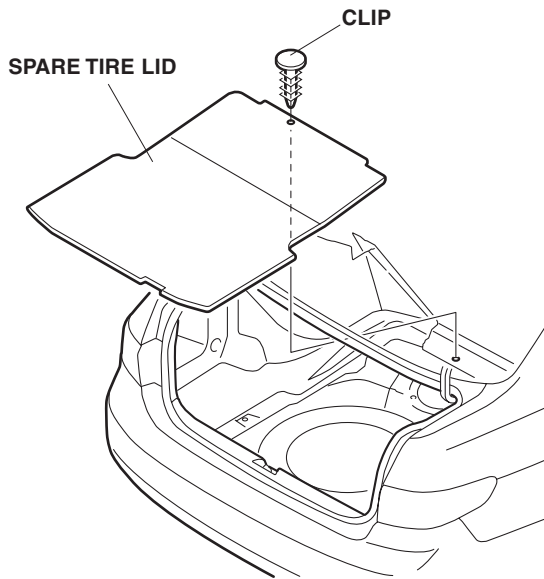

2. Remove the trunk weatherstrip from the edge of the trunk in the area shown, then remove the rear panel trim (four clips).

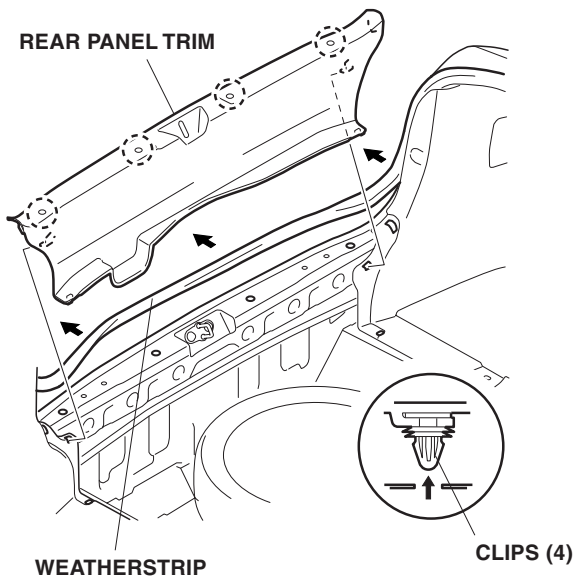

3. Open the jack cover, and remove the jack.
4. Remove the taillight access cover (three retaining tabs).

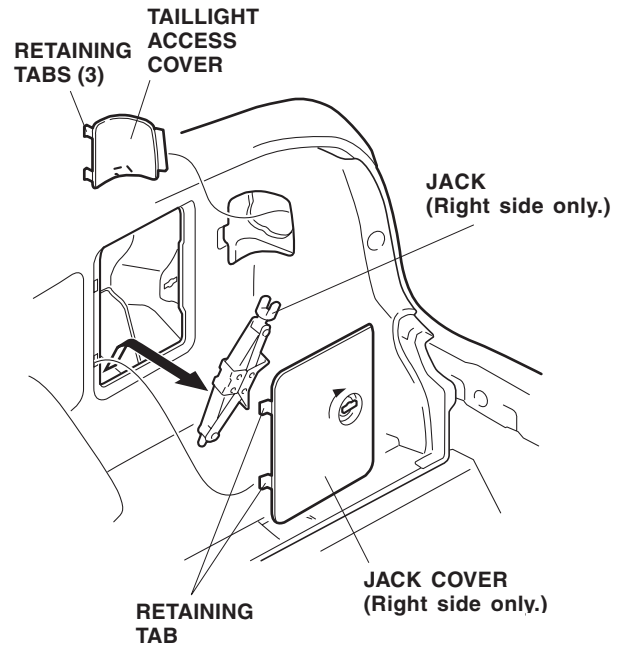

5. Measure the trunk side lining and mark the measurements with masking tape in the areas shown.

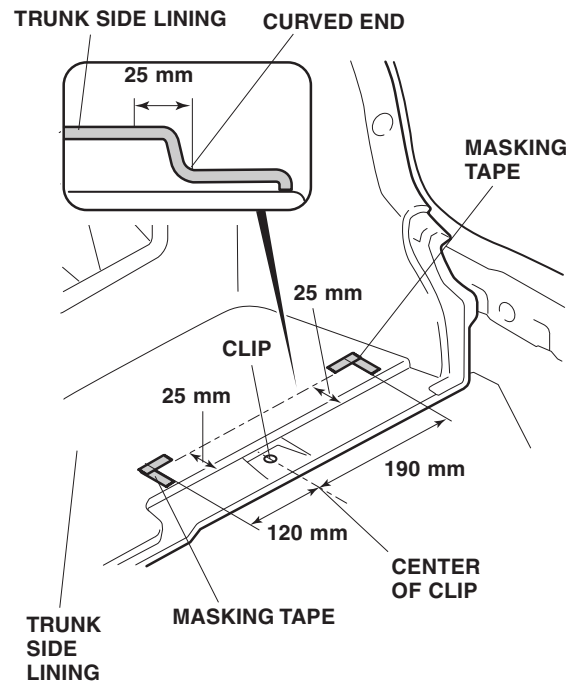

6. While wearing eye protection, drill 5 mm holes through the trunk side lining and rear floor panel as indicated by the masking tapes. First drill with a 3 mm drill bit, and finish with a 5 mm drill bit.

DRILL

First drill with a 3 mm drill bit, and finish with a 5 mm drill bit.

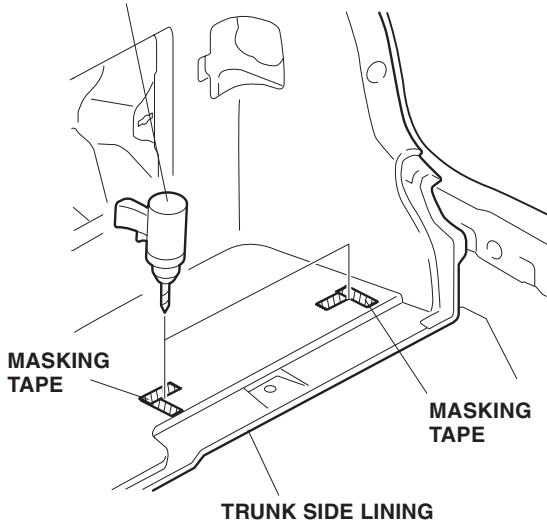

7. Repeat steps 5 and 6 to mark and drill holes in the left side trunk lining and rear floor panel.

8. Remove the three clips and trunk hook, then pull the right trunk side lining out away from the side.

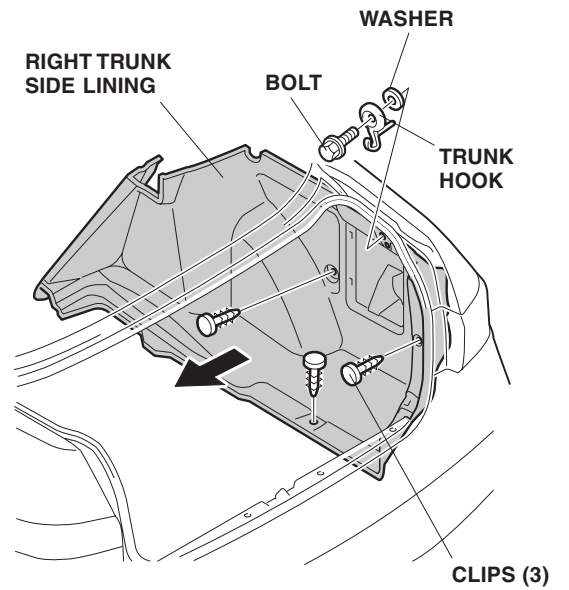

9. Remove the four clips, then pull the left trunk side lining out away from the side.

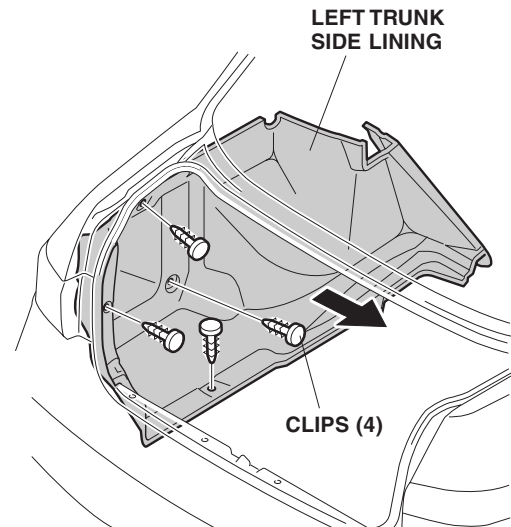

10. While wearing eye protection, and being careful not to damage the trunk area, enlarge the 5 mm you made in the trunk side lining to 26 mm using a hole saw. Enlarge the other sides trunk side lining the same way.

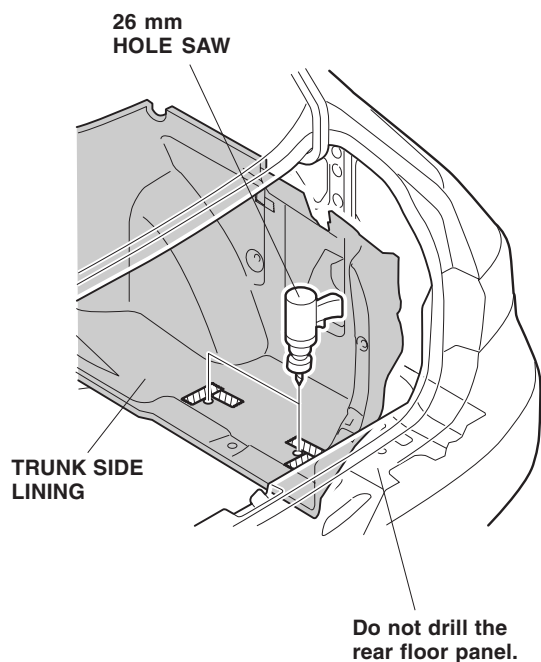

11. On the right side install the 6 x 32 mm washer-bolt into the hole in the right rear inside panel and secure with the nut. Install the bolt through the bolt hole shown location.

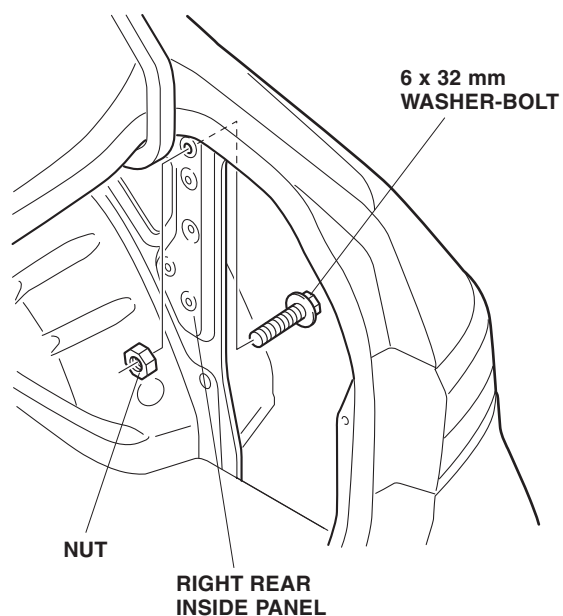

12. On the left side install the 6 x 20 mm washer-bolt into the hole in the left rear inside panel and secure with the nut.

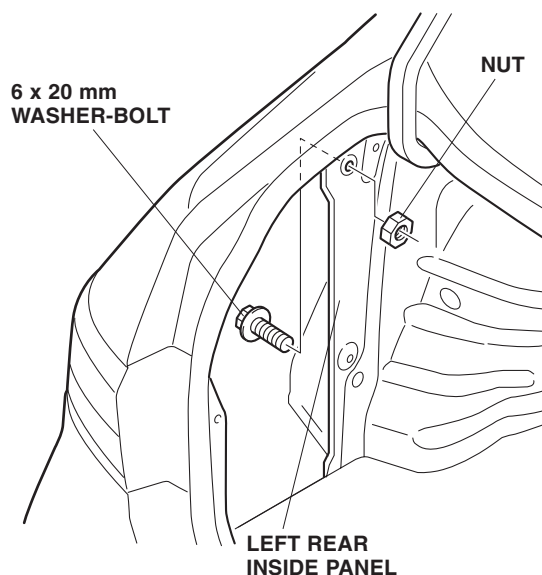

- Apply white paint to the end of the washer-bolt.

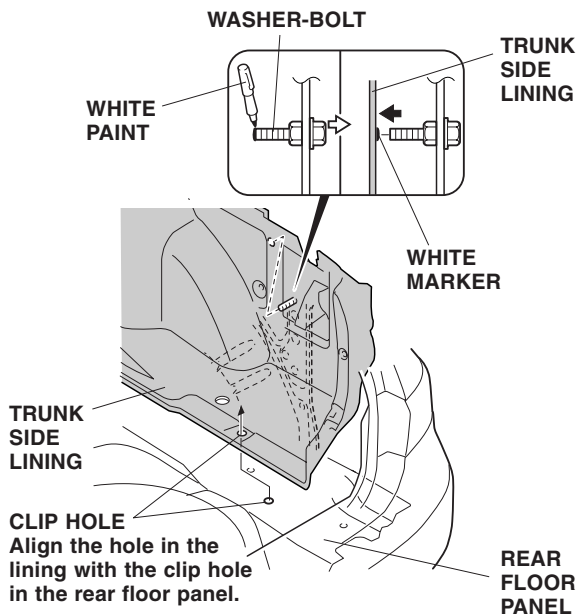

- Position the right side trunk lining on the rear floor and align the clip holes, then hold the lining firmly against the end of the washer-bolt so that the white paint is transferred to the trunk side lining.
- Using a pushpin, pierce a hole through the back of the right trunk side lining at the white mark. While wearing eye protection, drill a 10 mm hole through the hole you just made with the pushpin. First drill with a 3 mm drill bit, and finish with a 10 mm drill bit. Take care not to damage the rear inside panel.

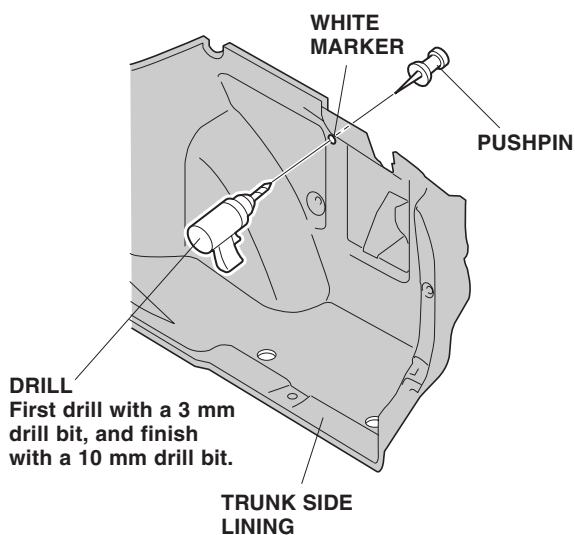

- Install the two self-tapping hooks with spacers through the holes you drilled in the rear floor panel. Tighten the self-tapping hooks securely.

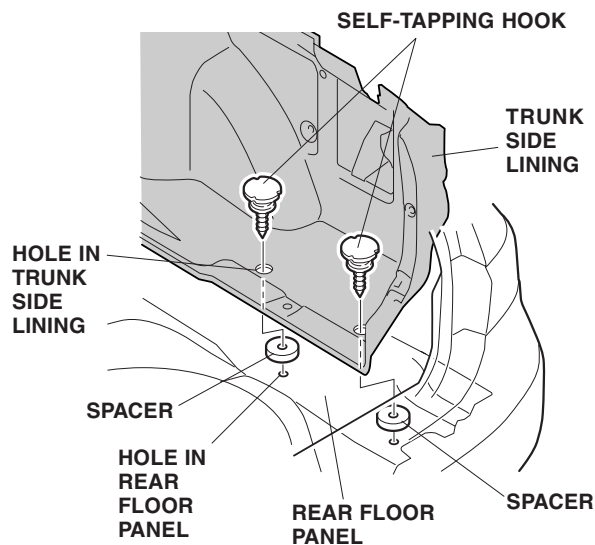

- Reinstall the right side trunk lining. Check that all clips are installed securely.
- Install an anchor to the washer-bolt you installed.

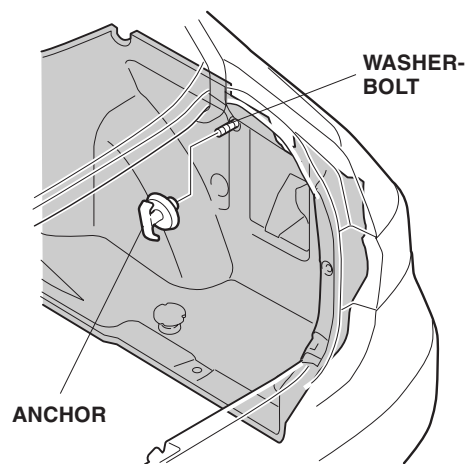

- Repeat steps 13 thru 18 to install the left side trunk lining.
- Reinstall all removed parts. Check that all clips and retaining tabs are installed securely without play or lifting.

Please give a copy of this page to your customer.

Install the cargo net to the self-tapping hooks and anchors according to the illustration that best serves your needs.

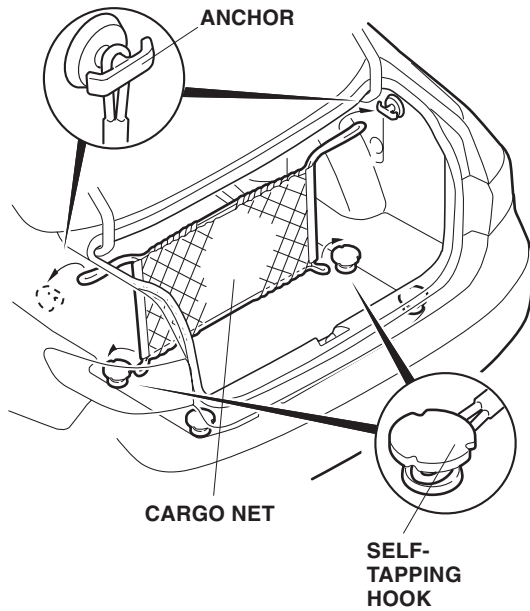
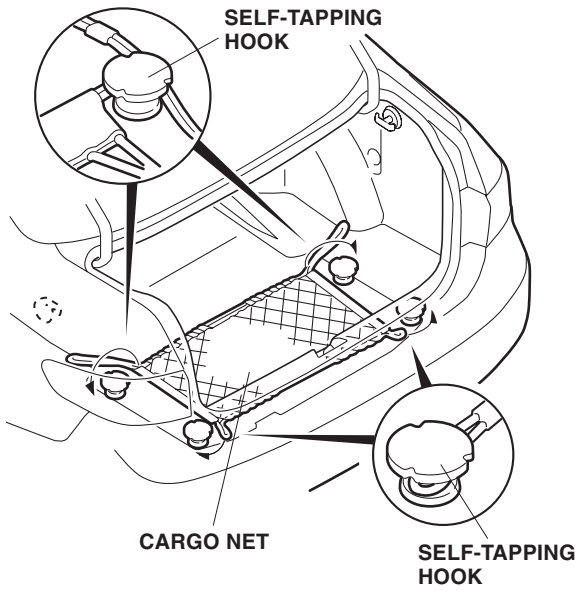

NOTE:

- Do not store large or fragile objects in the net.
- Do not store objects with sharp edges or corners, as they may damage the cargo net or the car. Wrap such objects in paper or a blanket so they will not contact the net directly.
- The hooks and anchors for the cargo net must not be used for any other purpose.